

ENGLISH

User Manual

Copyright

This manual is copyrighted with all rights reserved. No portion of this manual may be copied or reproduced by any means without the prior written consent of BRADY Worldwide, Inc.

While every precaution has been taken in the preparation of this document, BRADY assumes no liability to any party for any loss or damage caused by errors or omissions or by statements resulting from negligence, accident, or any other cause. BRADY further assumes no liability arising out of the application or use of any product or system described, herein; nor any liability for incidental or consequential damages arising from the use of this document. BRADY disclaims all warranties of merchantability of fitness for a particular purpose.

Trademarks

TLS2200™ and LabelMark/WIN™ are trademarks of BRADY Worldwide, Inc.

Microsoft and Windows are registered trademarks of Microsoft Corporation.

BRADY reserves the right to make changes without further notice to any product or system described herein to improve reliability, function, or design.

© 2000 BRADY Worldwide, Inc. All Rights Reserved
Revision C, printed March 2000
Software Version 3

W.H. BRADY
Wildmere Industrial Estate
Banbury
Oxon
England OX 16 7 GU

Tel: +44 (0) 1 295 228 200
Fax: +44 (0) 1 295 228 100

FCC Notice—U.S. Only

WARNING: This equipment generates, uses, and can radiate radio frequency energy. If not installed and used in accordance with the manufacturer's instructions, it may cause interference to radio communications. It has been tested and found to comply with the limits for a Class A computing device pursuant to Subpart J of Part 15 of the FCC rules, which are designed to provide reasonable protection against interference when operating in a commercial environment. Operation of this equipment in a residential area is likely to cause interference, in which case corrective measures will be at the owner's expense.

The user is cautioned that any changes or modifications not expressly approved by BRADY Worldwide, Inc. could void the user's authority to operate the equipment.

This is a Class A product. In a domestic environment this product may cause radio interference in which case the user may be required to take adequate measures.

Europe

This is a Class A product. In a domestic environment this product may cause radio interference in which case the user may be required to take adequate measures.

Canada

This Class A digital apparatus meets all requirements of the Canadian Interference-Causing Equipment Regulations.

BRADY Warranty

Our products are sold with the understanding that the buyer will test them in actual use and determine for him or herself their adaptability to his/her intended uses. BRADY warrants to the buyer that its products are free from defects in material and workmanship, but limits its obligations under this warranty to replacement of the product shown to BRADY's satisfaction to have been defective at the time BRADY sold it. This warranty does not extend to any persons obtaining the product from the buyer.

THIS WARRANTY IS IN LIEU OF ANY OTHER WARRANTY, EXPRESS OR IMPLIED INCLUDING, BUT NOT LIMITED TO ANY IMPLIED WARRANTY OF MERCHANTABILITY OR FITNESS FOR A PARTICULAR PURPOSE, AND OF ANY OTHER OBLIGATIONS OR LIABILITY ON BRADY'S PART. UNDER NO CIRCUMSTANCES WILL BRADY BE LIABLE FOR ANY LOSS, DAMAGE, EXPENSE OR CONSEQUENTIAL DAMAGES OF ANY KIND ARISING IN CONNECTION WITH THE USE, OR INABILITY TO USE, BRADY'S PRODUCTS.

YOU SHOULD CAREFULLY READ THE FOLLOWING TERMS & CONDITIONS OF THIS LICENSE AGREEMENT. IF YOU DO NOT AGREE WITH THESE TERMS & CONDITIONS, PLEASE PROMPTLY RETURN THIS PACKAGE FOR A FULL REFUND.

License Agreement

BRADY USA, Inc. (hereafter "BRADY") hereby grants you a non-exclusive, non-transferable license to use the software and accompanying documentation according to the following terms:

1. **LICENSE RESTRICTIONS:** You may not: 1) transmit the software over a network without an additional license; 2) modify, adapt, translate, reverse engineer, decompile, disassemble, create derivative works based on, or copy (except for one back-up copy) the software or the accompanying documentation; 3) rent, transfer, or grant any rights in the software or accompanying documentation without prior, express written consent of BRADY; or 4) remove any proprietary notices, labels, or marks on the software and accompanying documentation.
2. **NATURE OF THIS AGREEMENT:** This license is not a sale. Title and copyrights to the software, accompanying documentation, and any copy made by you remains the property of BRADY. Unauthorized copying of the software or the accompanying documentation, or failure to comply with the above restrictions, shall automatically terminate this license without further notice, and terminate your rights to use the software, and BRADY shall, in addition to its other legal remedies, be entitled to its reasonable attorney fees.
3. **LIMITED WARRANTY:** BRADY warrants that, for a period of one hundred and eighty (180) days from the date of delivery to you as evidenced by a copy of your receipt, the software, as furnished, under normal use, will perform without significant errors that make it unusable. BRADY's entire liability and your exclusive remedy under this warranty (which is subject to you returning the software to BRADY) will be, at the option of BRADY, to attempt to correct or help you around errors, to replace the software with functionally equivalent software or diskettes, or to refund the license fee of the software and terminate this agreement.

EXCEPT FOR THE ABOVE EXPRESS LIMITED WARRANTY, BRADY MAKES AND YOU RECEIVE NO WARRANTIES, EXPRESS, IMPLIED, STATUTORY OR IN ANY COMMUNICATION WITH YOU, AND BRADY SPECIFICALLY DISCLAIMS ANY IMPLIED WARRANTY OF THE WARRANTY THAT THE OPERATION OF THE PROGRAM WILL BE UNINTERRUPTED OR ERROR FREE.

Some states do not allow the exclusion of implied warranties so the above exclusion may not apply to you. This warranty gives you specific legal rights. You may also have other rights which vary from state to state.

4. **LIMITATION OF LIABILITY:** IN NO EVENT WILL BRADY BE LIABLE FOR ANY DAMAGES, INCLUDING LOSS OF DATA, LOST PROFITS, COST OF COVER OR OTHER SPECIAL, INCIDENTAL, CONSEQUENTIAL OR INDIRECT DAMAGES ARISING FROM THE USE OF THE PROGRAM OR ACCOMPANYING DOCUMENTATION, HOWEVER CAUSED AND ON ANY THEORY OF LIABILITY. THIS LIMITATION WILL APPLY EVEN IF BRADY HAS BEEN ADVISED OF THE POSSIBILITY OF SUCH DAMAGE. YOU ACKNOWLEDGE

THAT THE LICENSE FEE REFLECTS THIS ALLOCATION OF RISK.

Some states do not allow the limitation or exclusion of liability for incidental, or consequential damages, so the above limitation may not apply to you.

5. **General:** If the product is acquired under the terms of a 1) GSA contract - use, reproduction or disclosure is subject to the restrictions set forth in the applicable ADP Schedule contract; 2) DOD contract - use, duplication or disclosure by the Government is subject to restrictions set forth in subparagraph (c)(1)(ii) of 252.277-7013; 3) Civilian agency contract - use, reproduction, or disclosure is subject to 52.277-19(a) through (d) and restrictions set forth in this Agreement. Unpublished rights reserved under the copyright laws of the United States.

This Agreement shall be governed by, and interpreted under, the laws of the state of Wisconsin. This Agreement is the entire agreement between the parties and supersedes any other communications or advertising with respect to the software and accompanying documentation. If any provision of the Agreement is held invalid, the remainder of this Agreement shall continue in full force and effect.

Technical Support

Choose one of the following options to contact TLS2200™ system support provided by BRADY Worldwide, Inc.:

1. To speak with a Technical Support Representative, call +44 (0) 1 295 228 205.
2. FAX your inquiry to +44 (0) 1 295 228 105.
3. Contact BRADY's Technical Support Team on-line at: **support@brady.be**

Table of Contents

- Introduction.....11
 - Unpacking Your TLS2200™ Thermal Labeling System.....11
 - Saving Your Packaging.....11
 - TLS2200™ Thermal Labeling System Specifications.....12
 - Physical and Environmental Characteristics12
 - Certification12
 - Knowing Your Software Version Number13
- Quick Start Guide14
 - Summary of Steps14
- Working with Screens and Menus23
 - The Text Editor Screen23
 - The Setup Menu.....23
 - Setup Menu Options24
 - Setup Menu Tree.....27
- Creating Legends28
 - Using the <Enter> Key When Composing a Legend.....28
 - Default Font Size28
 - Changing the Font Size.....29
 - TLS2200™ Printer Fonts.....29
 - Clearing the Legend.....31
 - Saving and Recalling a Legend.....31
 - Function Keys32
- Printing Your Labels.....33
 - Adjusting Burn Temperature33
 - Setting Peel Time.....33
 - Printing Larger Labels33
 - Reloading Marker Rolls and Ribbons34
- Advanced Features.....35
 - Serialized Labels.....35
 - Legend Lists.....37
 - Continuous Printing—Terminal Block Labels.....43
 - Continuous Printing—Banners44
 - Default Font Size44
 - Fixed Length Banners.....45
 - Barcode Labels45
- Tutorial Guide.....48
 - T1: Creating a One-Line Legend, Component Marker48
 - T2: Creating a Component Label Utilizing Multiple Font Sizes49
 - T3: Creating a Wiremarker50
 - T4: Creating Serialized Wiremarkers.....51
 - T5: Creating a Label with Rotated Text, Printing Multiple Copies53
 - T6: Creating a Barcode Label54
 - T7: Creating a Serialized Barcode Label56
 - T8: Creating a Terminal Block Label57

T9: Creating a Patch Panel Label.....	59
T10: Creating a Continuous Label	61
T11: Creating a Banner Label of Fixed Length	62
T12: Creating a Legend List, Component Markers.....	63
T13: Creating a Legend List Utilizing Multiple Font Sizes and Rotations.	65
T14: Creating a Legend List, Wiremarkers, Printing Multiple Copies	67
T15: Creating and Recalling a Legend List, Barcode Labels.....	69
T16: Creating a Legend List, Recalling and Editing a Legend	71
T17: Creating a Legend List, Banner Legends	73
Maintenance.....	75
Cleaning the Drive Roller and Cutter.....	75
Cleaning the Print Head	75
Accessory Parts List.....	75
Appendix 1: Troubleshooting and Error Message Guide.....	76
Troubleshooting Guide	76
Error Messages.....	77
Appendix 2: Glossary of Terms	81
Appendix 3: Direct Printing from LabelMark/Win™	82

Introduction

Small in size, big in performance! Since the invention of thermal transfer technology, the idea has remained unchanged—bigger has always been better. Until now. BRADY introduces the TLS2200™ Thermal Labeling System. This hand-held thermal transfer printer is the new leader in the BRADY line of quality performance printers. Weighing in at just 1.32 kg (2.75 lbs.), it is the only thermal-transfer barcode/label printer that you can hold in just one hand.

Never before has there been a printer quite like the TLS2200 printer. It is so easy—simply choose the type of labels you want to print and load them in. The TLS2200 printer takes care of the rest. Thanks to its innovative smart-cell technology, the TLS2200 printer recognizes the label you are using and automatically adjusts itself, saving you a significant amount of setup time. As you will see, the TLS2200 printer is the first hand-held thermal transfer printer that is not only portable, quick, and easy to use, but uniquely intelligent as well. We are sure you will find it to be an extremely versatile and durable tool, useful for a great number of label-making needs.

Unpacking Your TLS2200™ Thermal Labeling System

Before you begin setting up the printer, verify you have received the following items in your packaging:

- TLS2200 Thermal Labeling System
- Hard Side Carrying Case
- Battery Pack
- Battery Charger
- Warranty Card
- Cleaning Card
- Font Size/Ribbon Cross Reference Guide Card
- Quick Start Reference Card
- Communications Cable
- User's Manual
- R6210 Ribbon
- Sample Label Roll (PTL-19-423)

Saving Your Packaging

The packaging surrounding your TLS2200 printer should be saved in the event of any future shipments of the printer and accessories.



WARNING: Never ship the TLS2200 printer without first removing the rechargeable battery pack from the printer **and** disengaging the print head.

If shipping both the printer and battery pack, remove the battery pack from the printer and place the items in the original shipping material before transporting.

TLS2200™ Thermal Labeling System Specifications

The TLS2200 printer has the following specifications:

- Weight 1.32 kg (2.75 lbs.)
- Thermal Transfer Print Mechanism 8 dots/mm (203 dpi)
- Optical Registration System for Precise Print Registration
- Elastomeric Keypad
- 2-Line by 16-Character Liquid Crystal Display
- Custom True Type Font (Arial)
- Labels up to 50.8 mm (2") Wide
- Print Width – 46 mm (1.81")
- Print Length – Over 1424 mm (56")
- Adjustable for six Different Liner Widths
- Prints 500 Labels Between Battery Charges
- Six Month Warranty

Physical and Environmental Characteristics

The TLS2200 printer has the following physical and environmental characteristics:

PHYSICAL	Metric Units	U.S. Units
Dimensions	305 x 95 x 114 mm.	12 x 3.75 x 4.5 in.
Weight (with battery pack)	1.32 kg	2.75 lb.

ENVIRONMENTAL	Operation	Storage
Temperature*	4° to 40°C (40° to 105°F)	-18° to 60°C (0° to 140°F)
Relative Humidity	20% to 95% (non-condensing)	10% to 80% (non-condensing)

*Exposing the TLS2200 printer to direct sunlight is not recommended.

Certification

The TLS2200 printer has the following certifications:

- FCC Class A Approved
- UL/CUL-listed Battery Charger

Knowing Your Software Version Number

The software in your TLS2200™ printer can be updated through the use of the Brady Device Loader. To determine the version number of the software currently loaded in your TLS2200 printer, watch the LCD screen as you turn the unit on. You will see one of the following welcome screens:

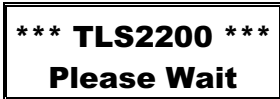

This is the welcome screen for a TLS2200 printer with version 1.0 software.



This is the welcome screen for a TLS2200 printer with version 2.0 software.



This is the welcome screen for a TLS2200 printer with version 3.0 software.

Quick Start Guide

This section guides you through the process of creating a label. Read the rest of this manual for detailed information on each of these steps, as well as other functions not listed here.



Note: It is suggested that you read *Appendix 2: Glossary of Terms* before you read this guide. This appendix acquaints you with the terms found in this manual that are used within the specific context of the TLS2200™ printer.

Summary of Steps

Following is a summary of the steps needed to create a label. A complete description of each step follows later in this section.

Step	Purpose of Step	Page
1	To charge the battery	14
2	To install the battery.	15
3	To turn the power on.	15
4	To select the marker and ribbon.	16
5	To install the ribbon cartridge.	17
6	To remove the marker roll.	18
7	To install the marker roll.	18
8	To type text.	18
9	To edit text.	20
10	To print the label.	22

Step 1. Charge the Battery

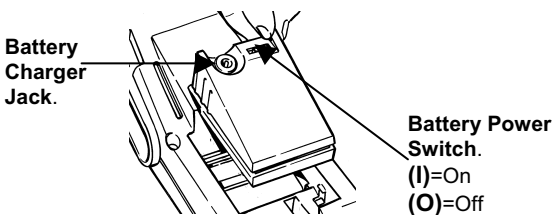

Note: The battery pack is shipped in an uncharged condition. Charge the battery for a minimum of five hours before operating the printer solely on battery power.

You can charge the battery pack while the battery power switch is turned *on* or *off*. The battery pack charges as long as the charger is plugged in. BRADY recommends that once the battery pack is fully charged, you should unplug the charger and operate the printer solely on battery power.

If the battery pack is completely discharged, connecting the charger does not provide enough power to run the printer. Recharge the battery pack before continued use.



WARNING: Disposal of the Battery Pack

The NiCad battery pack contains cadmium, a toxic element. The battery pack is considered hazardous toxic waste and must not be thrown away in the home or office garbage. Once the useful life of the battery is ended (one to three years), contact your local authorities for information regarding its proper disposal or recycling options.

Step 2. Install the Battery

1. Turn the battery power switch to the *off* (O) position.
2. Slide the battery release lever to the unlock position. (slide to left)
3. Drop the battery in as shown and slide forward.
4. Slide the battery release lever to the lock position. (slide to right)

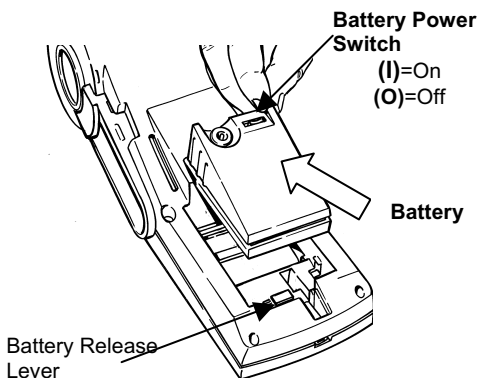

Step 3. Turn the Power On

Turn battery power switch to the *on* (I) position.

Step 4. Select Your Marker and Ribbon

Use the following chart to select the appropriate marker and ribbon for your task:

B #'s	Material	RIBBON SERIES			
		R4310	R4410	R6010	*R6210
B-109	Tag	●			
B-321	Polyolefin				●
B-342	Polyolefin	●			
B-351	Vinyl				●
B-400	Vinyl Cloth	●			
B-412	Polypropylene	△			●
B-422	Polyester		● UL/CSA	● UL/CSA	△
B-423	Polyester		● UL/CSA	● UL/CSA	△
B-424	Paper	●			
B-426	Polyimide	●			
B-427	Vinyl	●			●
B-428	Polyester	●UL/CSA			
B-430	Polyester		● UL/CSA	● UL/CSA	△
B-435	Polyester		● UL/CSA	● UL/CSA	
B-437	Tedlar®	●			△
B-439	Vinyl		●		△
B-457	Polyimide		● UL	● UL	
B-459	Polyester		● UL/CSA	● UL/CSA	
B-473	Polyester		● UL/CSA	● UL/CSA	△
B-477	Polyimide		● UL	● UL	△
B-483	Polyester		●UL/CSA	●UL/CSA	△
B-499	Nylon Cloth	● UL/CSA			△
B-642	Tedlar®	●			△

Tedlar® is a registered trademark of Dupont

Key:

Code	Description
●	Recommended ribbon for use with respective material.
△	Acceptable ribbon for use with respective material.
UL	This material is UL recognized with its respective ribbon.
CSA	This material is CSA approved with its respective ribbon.
UL/CSA	This material is UL & CSA approved with its respective ribbon.
*	R6210 ribbon included with printer.

Step 5. Install the Ribbon Cartridge

1. Remove cartridge from the bag. Avoid touching or creasing the ribbon.
2. Remove any ribbon slack by rotating take-up spool end counter-clockwise.
3. Slide ribbon cartridge firmly into printer. (Locking lever must be in unlock position – see below.)
4. Push the locking lever towards the back of the printer to close the print head and lock the ribbon cartridge in place.

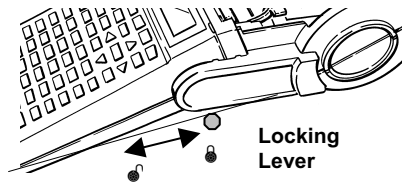
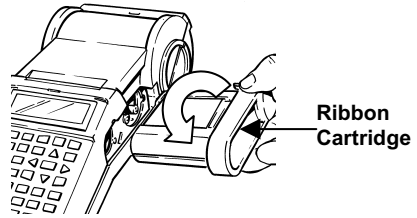

Step 6. Remove a Marker Roll

1. Cut off printed labels with the cutter lever.
2. Open the roll door.
3. Slide the locking lever to the unlock position.
4. Back the markers out of the material guide slots.
5. Pull the marker roll out of its cradle.

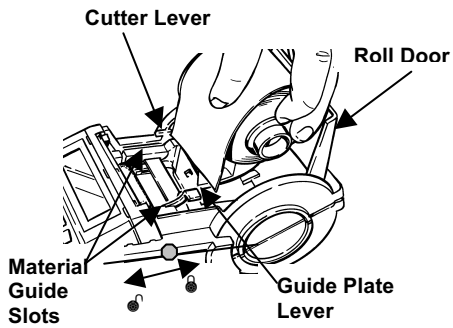

Step 7. Install a Marker Roll

1. Slide the locking lever to the lock position.
2. Turn the power switch on.
3. Open the roll door.
4. Pressing the guide plate lever down, slide and snap it into a notch that matches your marker roll width.
5. Making sure labels unwind from the top, snap the marker roll firmly into cradle.
6. Press **<Enter>** to clear the "ERROR No Label Present" message.
7. Feed leading edge of marker roll through the guide slots.
8. Press **<Feed>**. (Continue to manually push marker roll edge until it catches.)
9. Close the roll door.

Step 8. Type Text

Use the following guidelines when typing text:

Text Type	Guidelines
Alphabetic letters	Type lower-case letters (a-z) by pressing the appropriate keys. Press the <Space> key to add a space between words. Type an upper-case letter by holding down the <Shift> key while typing the letter. To type many upper-case letters in a row, turn the caps lock feature on by pressing the <Func> + <Cap Lock> keys.
Numbers	Type numbers (0-9) by pressing the desired keys.
Secondary characters	A yellow secondary character appears on the upper-right of each text key. Type one by first pressing the <Func> key, then press the desired secondary character key. For all key combinations you must press the first key first. Then, while still holding it down , press the second key.
Accented Characters	To place an accent mark over a vowel, type the mark first followed by the letter itself. (Note: The tilde (~) is to be used with the letters A,a or N,n only.)

The LCD displays two lines of text with 16 characters on each line. The first line always displays the **status bar**, which includes font and character positioning information (see below).

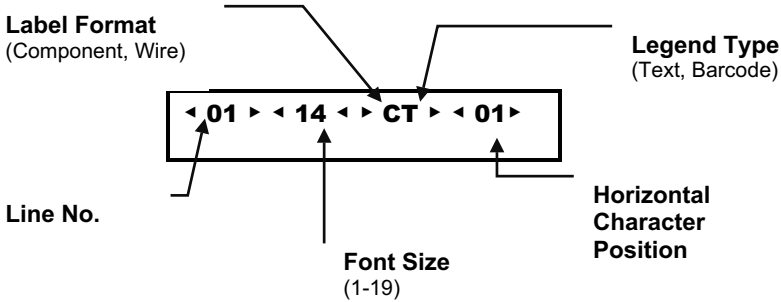

As you type characters, they appear on the liquid crystal display (LCD) at the cursor's position. Depending on the installed marker size and font size selected, you can have up to 23 lines on a single label and 50 characters on a single line. The cursor marks your current typing or editing position.

If you are entering more than 16 characters on a line, you can not see the entire label until it is printed. The arrow keys allow you to move the cursor around the LCD. As the cursor moves beyond the 16th character, the screen scrolls to display the remaining text for the label line:

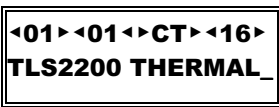

The status bar indicates the cursor is located at the 16th character position.

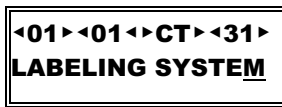

As you continue to enter text, the screen scrolls to allow the entry of the remaining text (underlined *M* is at cursor position 31).

Step 9. Edit Text

Changing Font Sizes

At any time during the text entry or editing process, you can change the font size for the label line displayed on the text editor screen. This can be done on a line-by-line basis only. To change the font size for a given line, simply press **<Shift> + <▲>** or **<Shift> + <▼>** respectively to increase or decrease the font size.

Cursor and Editing Keys

Use the following keys to edit your legend:



For key combinations (for example, Shift + ◀) you must press the first key first. Then, **while still holding it down**, press the second key.

Keys	Description
Enter	<ul style="list-style-type: none">• Activates a screen selection.• When composing a legend, inserts a non-visible end-of-line character and moves the cursor down to the next line.• Clears system messages from display.
▶	Moves the cursor one character to the right. If at the rightmost position on the display, the display is scrolled one character to the left and the cursor remains at the rightmost position.
◀	Moves the cursor one character to the left. If at the leftmost position on the display, the display is scrolled one character to the right and the cursor remains at the leftmost position.
▲	Displays the previous line of text (if any).
▼	Displays the next line of text (if any).
Shift + ▶	Skips to the beginning of the next word.
Shift + ◀	Skips to the beginning of the previous word.
Delete	<ul style="list-style-type: none">• While in text editor, deletes the character at the cursor position.• Backs out one level in the Setup Menu tree.• Terminates the printing of markers.
Shift + Delete	Backspaces as it deletes characters. If cursor is at the first character position on a line, the carriage return is deleted and any text on the line is appended to the text on the previous line.
Legend Clear	Clears all characters on the current legend line.
Shift + Legend Clear	Clears all characters on the legend.
Shift + Form Clear	Deletes all characters and lines on the legend, and resets the font size to the default value.
Cap Lock	Toggles between uppercase and lowercase characters. Note: Current Cap Lock status is retained when unit is turned off.
Space Bar	Moves the cursor one position to the right. Inserts a space at the

Keys	Description
	current cursor position.

Step 10. Print Labels

To print:

- the contents of your legend, simply press the **<Print>** key.
- multiple copies of your legend, press **<Func> + <Multi Print>**. The screen prompts for the “No. of Copies?”. Enter a number from 1-250 and press **<Enter>**.



Note: Press the **<Feed>** key if you want to feed one marker without printing.

When a label has printed out use the built-in cutter to remove it. Use the external lever to cut between labels.



WARNING: *Never use the cutter with BRADYSleeve label rolls!* The printer always advances the last printed sleeve to the appropriate position to allow tear-off at the perforation.

Working with Screens and Menus

The Text Editor Screen

Each time the printer is turned on, an initialization routine is performed, then the Text Editor screen appears. This screen is the *home base* of any processing you perform with the TLS2200™ printer. To change any of the parameters previously defined, you must access the software features of the printer by calling up the Setup Menu from the Text Editor screen. *For more information on setting the Setup Menu options, refer to the section titled The Setup Menu on page 23.*



WARNING: To ensure that text is not deleted, always set the rotation value *before* entering your legend.

After setting the label parameters, you can begin entering the text of your legend.

As previously mentioned, the LCD displays a maximum of one line of text and 16 characters on the screen at any one time. If a line consists of more than 16 characters, the LCD automatically shifts to the right to allow you to enter and view additional characters. Characters can be entered on the text editor screen in insert mode only.

The Setup Menu

The Setup Menu allows you to set and adjust label formatting or printing defaults, and specify the language in which your prompts and menus should appear. You can access any of the Setup Menu functions by following the steps below:

1. Press the **<Func>** + **<Setup>** keys to access the Setup menu. The Setup Menu appears on the LCD.
2. Use the **<▲>** and **<▼>** keys to move through the menu choices. The cursor indicates the currently selected option.



Note: A downward pointing arrow on the right side of the LCD indicates there are more selections available below the currently highlighted choice.

An upward pointing arrow indicates there are more selections available above the currently highlighted choice. Up and down arrows appearing simultaneously indicate there are more selections available both above and below the currently highlighted choice.

3. Press the **<Enter>** key to access the sub-menu choices.
4. Use the **<▲>** and **<▼>** keys to move through the sub-menu choices. The cursor indicates the currently selected option. Press **<Enter>** to select a sub-menu.
5. Use the **<▲>** and **<▼>** keys to select the desired menu setting, then press **<Enter>** to save your change. To exit without saving the change press either the **<Exit>** key (sends you back to the text editor screen) or the **<Delete>** key (backs you out one level in the menu tree).

Setup Menu Options

The Setup Menu contains seven sub-menu options for formatting and printing your labels and setting your language preference for the menus and prompts. Many of these options provide you with ways to customize the formatting of your labels. *Refer to the Setup Menu Tree section on page 27.*

Printer

The Printer Menu contains the following user options:

Option	Description
Top Margin Adj.	Adjusts first vertical print position from top of label. Values range from -0.625 mm (-0.0246 in) to +1.375 mm (0.05412 in).
Left Margin Adj.	Adjusts first horizontal print position from left edge of label. Values range from -0.625 mm (-0.0246 in) to +1.375 mm (0.05412 in).
Cut Feed Adj.	Adjusts vertical cut position between labels. Values range from -1 mm (-0.03936 in) to +1 mm (0.03936 in). The < ▲ > and < ▼ > keys increase/decrease value by 0.125 mm increments (1 dot).
Peel Time	Determines how long (in seconds) a label remains in peel position before moving back to cut position. Ranges from 2 to 9 seconds. Default = 5 sec. Note: Peel time option is not supported for BRADYSleeve and PermaSleeve marker parts.
Burn Temp	Determines the print density on the label. Setting ranges from -5 (lightest) to + 5 (darkest). Default = 0
Clean Printer	Performs printer cleaning routine. Use this option with the cleaning card shipped with the unit.

Barcode

The Barcode Menu contains the following user options:

Option	Description
Bar Height	Sets the height of the Code 39 barcode. Setting ranges from 1 mm (0.03937 in) to 26 mm (1.02362 in). Default = 1 mm. Narrow bar width = 2 dots (.25 mm). Barcode Ratio = 2 to 1
Human Readable	Determines whether the barcode is printed along with human readable text. Toggles between on and off. Font size ranges from 2 (5 point) to 9 (14 point). Default = off.

Continuous

The Continuous Menu contains the following user options:

Option	Description
Terminal Block	Adjusts the terminal block repeat value. Setting ranges from 5 mm (0.19685 in) to 46 mm (1.81102 in). <▲> and <▼> keys increase/decrease value by 0.125 mm increments (1 dot). <Shift> + <▲> and <Shift> + <▼> increase/ decrease value by 1mm increments (8 dots).
Banner	Sets the orientation of the legend text on the banner. Toggles between vertical and horizontal.
Fixed Length	Adjusts the maximum length of the banner. Setting ranges from 32 mm (1.02362 in) to 305 mm (12.28346 in). <▲> and <▼> keys increase/decrease value by 13 mm (.51 in) increments. <Shift> + <▲> and <Shift> + <▼> increase/ decrease value by 26 mm (1.02 in) increments.

Style

The Style Menu contains the following user options:

Option	Description
Rotation	<p>Sets the rotation in one of four orientations. 0°, 90°, 180°, and 270°. Default orientation is dependent on the marker roll loaded in the unit.</p> <p>Always select the rotation value <i>before</i> entering the text for your label. A change to the rotation value causes the following to occur:</p> <ul style="list-style-type: none"> • All characters and lines on a legend are deleted. • The cursor moves to the first character position on line one. • The font is set to the default size for the marker. <p>Note: Rotation option is not supported for BRADYSleeve, PermaSleeve, and pre-printed marker parts (defaults to 0°).</p>
H Justify	Sets the horizontal justification of the legend. Options are: Left, Center, and Right. The marker roll loaded in the unit determines the default setting.
V Justify	Sets the vertical justification of the legend. Options are: Top, Center, and Bottom. The marker roll loaded in the unit determines the default setting.
Format	<p>Sets the label format. Options are: Component or Wire. Default = component.</p> <ul style="list-style-type: none"> • The component label format is designed to print all of the lines of a legend one time before advancing to the next marker. • The wire format is designed to automatically repeat the text of a legend down the length of a marker as many times as possible, considering the number of lines available in the marker.

Serial

The Serial Menu contains the following user options:

Option	Description
Standard	Defaults serial number scheme to decimal (0-9) or alpha (A-Z, a-z) based on character type entered.
Octal	Defaults serial number scheme to octal (Base 8). 0-7 numeric serialization.

Language

The Language Menu contains the following user options:

Option	Description
English	All menu options appear in English.
Português	All menu options appear in Portuguese.
Deutsch	All menu options appear in German.
Español	All menu options appear in Spanish.
Italiano	All menu options appear in Italian.
Français	All menu options appear in French.
Nederlands	All menu options appear in Dutch.

Units

The Units Menu allows you to set the unit of measure for the following Setup Menu options (Top Margin Adj., Left Margin Adj., Cut Feed Adj., Bar Height, Terminal Block, and Fixed Length):

Option	Description
Inches	Sets the units of measure to inches.
Metric	Sets the units of measure to millimeters.

Peripheral Mode

Peripheral Mode is a new option accessible one of two different ways. It is available on the TLS2200 Setup Menu, or you can use the <Func>+<Exit> key combination from the text entry screen. This option allows you to use the TLS2200 printer along with BRADY's LabelMark/WIN™ V1.2 or greater software to print labels that are created and stored on your PC.

Once the TLS2200 is in Peripheral Mode, pressing any key will return it to its normal operating mode



Note: Refer to page 82 for more information about using LabelMark/WIN™.

Setup Menu Tree

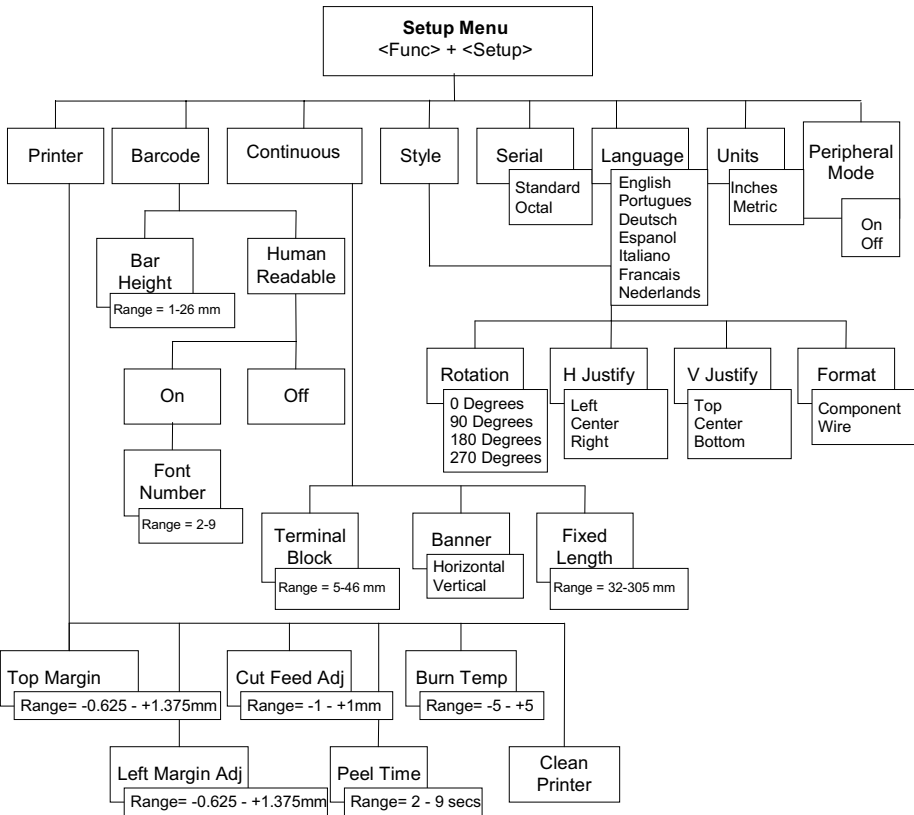

To use the menu:

- Press the <◀> and <▶> keys to move through the menu choices and to increase/decrease values within the range.
- Press the <Shift> + <◀> and <Shift> + <▶> keys to increase/decrease values within the range by larger steps.
- Press <Enter> to select and save menu option choices.
- Press <Exit/Delete> to exit a menu without saving changes.

Creating Legends

Using the <Enter> Key When Composing a Legend

It is not necessary to press the <Enter> key after entering the last line of text in your legend. Pressing the <Enter> key instructs the printer to reserve space for a new line of text (notice the cursor advances to the next line). Even if characters are not entered on this new line, the printer assumes the blank line is valid. As a result, markers are printed with the blank line, which leads to uncentered legends.

When the <Enter> key is pressed at the end of a line, a non-visible end-of-line character is inserted at the cursor. Characters entered after the cursor fall to the next line. This end-of-line character can be deleted by positioning the cursor over the first character position on the following line and pressing the <Shift> + <Delete> keys. This deletes the carriage return, moves up the text located on the second line, and appends the text on the first line. Any remaining lines of text also move up one line.



Note: The <Shift> + <Delete> command deletes the carriage return and appends text to the previous line only if *all* characters on the current line fit on the previous line. If the text can not fit, the carriage return is not deleted and all text remains on the current line.

Default Font Size

The TLS2200™ printer allows you to choose the font size for each individual line of text on your label (one size per line). The font size is always displayed on the status bar located on the first line of the LCD.

When a marker roll is loaded and the unit is turned on, the TLS2200 printer reads the marker size information stored in the smart-cell on the marker roll core. This information is used to automatically set an initial font size for your label. The method used to set this default is intended to help approximate an optimal starting point for sizing your text. It is as follows:

Marker Width	Default Font Size
< 12.7 mm (0.5 in.)	Largest size that allows four characters to fit on a label line
≥ 12.7 mm (0.5 in.)	Largest size that allows eight characters to fit on a label line



Note: For continuous printed labels (banners), the default font size is the largest font that prints on the selected marker width in horizontal orientation.

Once the font is set for a label line, the size remains the same for any new lines that follow (example, font size set at 8 for line one, press <Enter> to add line two, font size remains at size 8). The font size remains at the size you choose until you decide to change it.

Changing the Font Size

At any time during the text entry or editing process, you can change the font size for the label line displayed on the text editor screen. This can be done on a line-by-line basis only. To change the font size for a given line, simply press **<Shift> + <▲>** or **<Shift> + <▼>** respectively to increase or decrease the font size.

Selectable font sizes range from 1 (4 point) to 19 (72 point). The maximum font size selectable for a particular label line depends on several factors including marker size, number of characters of text entered on the label line, number of lines of text entered on the label, and the font sizes chosen for the other label lines.

If at any time you attempt to enter too many characters on a label line, the message “Reduce Type Size” flashes on the display. To allow more characters to fit on the line, press **<Shift> + <▼>** to decrease the font size.

Text already entered on a line can be switched from *text* to *barcode* mode and vice versa. If the size of the barcode, or text being switched to, does not fit on the marker, you encounter the message “Reduce Type Size” when you attempt to print the label. You must scroll to the line where the switch was made, reduce the size of the font (if text) or bar height (if a barcode), and print again.

If you press the **<Enter>** key and it no longer moves the cursor down to another line, you have attempted to enter more lines on the label than can fit. To add more lines, press **<Shift> + <▼>** to decrease the font size of the existing lines.

TLS2200™ Printer Fonts

The following fonts are available on the TLS2200 printer:

FONT NUMBER	POINT SIZE	PRINT SAMPLE
1	4	BRADY 12345
2	5	BRADY 12345
3	6	BRADY 12345
4	7	BRADY 12345
5	9	BRADY 12345
6	10	BRADY 12345
7	11	BRADY 12345
8	13	BRADY 12345
9	14	BRADY 12345
10	17	BRADY 12345

FONT NUMBER	POINT SIZE	PRINT SAMPLE
11	20	BRADY 12345
12	23	BRADY 12345
13	26	BRADY 12345
14	28	BRADY 12345
15	36	BRADY 123
16	45	BRADY 1
17	51	BRADY
18	56	BRADY
19	72	BRADY

Clearing the Legend

Use the following keys to clear the legend:

Keys	Description
<Legend Clear>	Clears all characters from the currently displayed label line while keeping the font size unchanged.
<Shift> + <Legend Clear>	Clears all characters on the legend while keeping the font size for all label lines unchanged.
<Shift> + <Form Clear>	Deletes all characters and lines on the legend, resets the font size to the default, and positions the cursor in the first character position on line one.

Values set in the Setup Menu (such as rotation, or horizontal and vertical justification) remain unchanged when performing any of the above actions or when you turn the unit off. Values change to the default values if a new marker roll with a different marker size is loaded into the unit.

Saving and Recalling a Legend

Any legend entered on the text editor is retained when the unit is turned off. Turn the unit back on and the legend reappears on the display. This rule holds true only if the part number of the marker roll loaded in the unit is not changed while the unit is turned off. If the TLS2200™ printer detects a marker size change when turned on, or if a different marker size is loaded while the unit is on, text on the display is cleared and the default font size is set.

Once you have finished entering and editing your text, you may wish to save your legend for retrieval at some later point in time. The TLS2200™ printer allows you to save legends to a list. See the Legend Lists section on page 37 for more information.

Function Keys

The use of each function key is described in the chart below:

Key	Description
Feed	Advances to the next marker.
Print	Prints the legend.
Multi Print	Prints multiple copies of the legend (1-250).
Serial	Serializes legend starting with the character at the cursor.
Exit	Exits you back to the text editor screen from any Serial, Multi Print, Setup Menu, or List Menu screen.
Peel	Advances label to peel position. Note: You cannot use this function with PSPT label rolls (PermaSleeve).
Barcode	Toggles legend type status (Text, Barcode).
Shift + ▲	Increases font size.
Shift + ▼	Decreases font size.
Shift + Wire	Toggles label format (Component, Wire).
Setup	Displays Setup Menu options.
Save	Saves the currently displayed legend to a legend list.
Recall	Recalls the previously saved legend to a legend list.
List	Displays List Menu.
Form	RESERVED FOR FUTURE USE.
Form Clear	RESERVED FOR FUTURE USE.

Printing Your Labels

Adjusting Burn Temperature

The burn temperature setting can be adjusted to darken or lighten your printed legend. Cases where adjustments are needed should be rare as the TLS2200™ printer automatically optimizes the burn temperature based on the material loaded in the unit.



Note: The burn temperature is automatically reset to its default setting of 0 each time the unit is turned off. *To obtain further information on adjusting the burn temperature, refer to The Setup Menu section on page 23.*

Setting Peel Time

After your label(s) are printed, the TLS2200 printer feeds the last printed label to the cut-off position. If you wish to remove (peel) the last printed label from the liner without cutting, the peel function can be used. Simply Press **<Func> + <Peel>** on the keypad and the unit advances the last printed label forward to the peel position. Depending on how the default is set, you have from 2 to 9 seconds to peel the label from the liner before it returns to the cut-off position. *For more information on setting the peel time, refer to The Setup Menu section on page 23.*



Note: The peel time option is not supported for BRADYSleeve and PermaSleeve label parts. After printing, BRADYSleeve advances to the tear-off position and PermaSleeve advances to the cut position.

Printing Larger Labels

Die cut label formats greater than 1.9" x 2.0" will print with version 2 software or higher. If you are using version 1 software, you will be able to print larger labels, but only up to the printable area limits of 1.81" x 1.81". *Refer to **Error! Reference source not found.** for help with installing new software on your TLS2200 printer.*

Reloading Marker Rolls and Ribbons

If the marker roll runs out of labels while printing, the TLS2200™ printer stops printing and the following message appears:

“Error Out of Label”

When the marker roll runs out, the print job is permanently cancelled. Any legends remaining to be printed are aborted. To continue printing, follow the instructions below.

1. Using the cutter mechanism, cut-off any labels that have already printed.
2. Pull the ribbon cartridge-locking lever towards the front of the printer to open the print head.
3. Pull any remaining markers out through the top of the printer.
4. Install a new marker roll. *For instructions, refer to the Install a Marker Roll section on page 18.*
5. Initiate a new print job to continue from where the previous one ended.

If the ribbon runs out while printing, the TLS2200 printer stops printing and displays the following message:

“Error Out of Ribbon”

Similar to the situation with marker rolls, when the ribbon cartridge runs out of ribbon, the print job is permanently cancelled. Any legends remaining to be printed are aborted. To continue printing, insert a new ribbon cartridge, then initiate a new print job to continue from where the previous one ended.



Note: When a marker roll or ribbon cartridge runs out, the legend entered on the LCD continues to display. This allows you to make a marker roll/ribbon replacement without losing your text. However, the display is cleared if the size of the markers on the new marker roll differs from those on the roll being replaced.

Advanced Features

Features outlined in this section pertain to advanced user options. You will find instructions for generating serialized, legend list, terminal block, and barcode labels.

Serialized Labels

This section discusses making serialized labels with the TLS2200™ printer.

Serialization

Legends you create with the TLS2200 printer can be serialized both numerically and alphabetically. Serializing characters in a legend results in a series of markers that increment by one number and/or one letter.

The TLS2200 printer allows you to create two different types of serialization patterns:

Pattern	Description
Standard	Defaults serial number scheme to decimal (0-9) or alpha (A-Z, a-z) based on character type entered.
Octal	Defaults the serial number scheme to octal (Base 8) 0-7 numeric serialization.

Your serialization type defaults to either standard or octal based on the selection you choose from the Setup Menu. *For instructions on how to set the serial default, refer to The Setup Menu section beginning on page 23.*

To create labels containing serialized data, follow the instructions below:

1. Enter the text to be serialized on the appropriate legend line.
2. Use the < ◀ ▶ > key to position the cursor over the last character in the legend to be serialized.
3. Press <Func> + <Serial> on the keypad. The screen prompts you to enter the number of times to increment the serial number with “No. to Serial?”.
4. Enter the number of times to increment the serial number and press <Enter>. The screen prompts you to enter the number of copies of each number to print with “No. of Copies?”
5. Enter the number of copies to print and press either <Enter> or <Print>. Your serialized markers are printed.

General Guidelines for Serializing

Use the following guidelines for serializing:

- Both lowercase and uppercase characters can be serialized.
- Serialized characters can be incremented only (cannot decrement).
- You can choose only one serial type per label (standard or octal).

- Serialized text is limited to one line and one sequence per label.
- The printer first serializes the character the cursor is highlighted on when the **<Func>** + **<Serial>** keys are pressed. When this character reaches its maximum value (9, z, or Z if standard, 7 if octal), the character immediately to the left is incremented, and the right most character cycles back to its minimum value (0, a, or A if standard, 0 if octal).
- Once a serialized character has reached its maximum value and the next character encountered to the left is a non-serializable character (such as a space, accented character, or symbol), the serial pattern cycles back to begin incrementing again from the rightmost serialized character.
- After printing a series of serial characters, the editor displays the next logical character in the serial pattern (example: Print 1 to 5. After print job is completed, editor displays 6).

Legend Lists

This section discusses making legend lists with the TLS2200™ printer.

What Is A Legend List?

A legend list consists of one or more legends stored under a list name. The storage capability of the TLS2200™ allows you to create, select, print, and edit legend lists.

It is recommended that you review the following terminology before you start working with legend lists:

Term	Definition
Legend —	The actual text to be printed on a marker. The legend appears on the Text Editor screen and can be stored in memory.
Legend List —	One or more legends stored under a list name.
Active Legend List —	A list becomes active when you create or select it. See <i>Creating a New List</i> and <i>Selecting a List</i> later in this section. A list that has been activated is ready to be printed or edited.
Recalled Legend —	A legend is recalled when you press <Func>+<Recall> or <Func>+<Shift>+<Recall> from within an active legend list. See <i>Editing a List</i> later in this section. A legend that has been recalled is ready to be edited.

General Guidelines for Legend Lists.

Use the following guidelines for legend lists:

- Legends for legend lists are created following the same guidelines as non-list legends.
- All style features accessible through the Setup Menu are available when creating legends for lists.
- Individual legends within legend lists can have different styles.
- You cannot save serialized legends to a list.
- The maximum number of legends you can save to a list will vary depending on how much memory the legends in your list use. The amount of memory used by a legend is dependent on certain variables such as the number of lines in the legend and the number of characters per line. For example, if your list contains legends that all have five lines and eight characters per line, you could save approximately 800 total legends to memory. If your list contains legends that all have one line and eight characters per line, you could save over 2,700 total legends to memory.
- A maximum of 10 legend lists can be stored in the printer at any one time.

The List Menu

To bring up the List menu, press **<List>** on the keypad. The List menu contains the following user options:

Option	Description
Select	Activates a list for editing or printing.
Create	Creates a new list.
Print	Prints a list.
Edit	Toggles either <i>on</i> or <i>off</i> . Edits a list when: <ul style="list-style-type: none">• a part is not installed in the printer.-or-• a part other than the part the list was created for is installed in the printer.
Delete	Deletes a list from memory.

Creating a New List

To create a new list, follow the instructions below:

1. Press **<List>** to access the List Menu.
2. Press the **<v>** key once to select *Create*, then press **<Enter>**.

If the error message “Memory Full” displays on the Text Editor screen, the maximum number of lists (ten) is already saved in memory. In order to proceed, you must delete one or more lists from memory. Refer to *Deleting a List* later in this section for instructions.

3. At the prompt “Enter List Name”, enter a name for your new list, then press **<Enter>**. A list name of up to 16 character is allowed. All the characters on the keypad are valid for list names.
4. At the prompt “Enter Part No.”, enter the entire part number as it appears on the end of the marker roll core. For example, PTL-19-423.
5. Press **<Enter>**. The Text Editor screen appears.



The list is created specifically for the part number entered at the time the list was created. **You cannot create a list unless a marker roll is loaded.**

6. Enter text to create the first legend for your list.
7. Press **<Func>+<Save>** to save your legend to the list.

If the error message “Memory Full” displays on the Text Editor screen, the memory has reached capacity. In order to proceed, you must either delete one or more legends from a list, or delete one or more lists from memory. Refer to *Deleting a List* later in this section for instructions. To delete a legend from a list, press **<Func>+<Shift>+<Delete>**.

8. Press **<Shift>+<Legend Clear>** to clear the text from the Text Editor screen.



Pressing **<Shift>+<Legend Clear>** deletes all text in the legend from the Text Editor screen. Press **<Legend Clear>** to delete text from only one line (the line currently displayed).

Once a legend is saved to a list, pressing **<Legend Clear>** or **<Shift>+<Legend Clear>** only deletes text from the screen, not from the list. Refer to *Editing a List* for instructions on deleting legends from a list.

9. Enter text for a second legend.
 10. Press **<Func>+<Save>** to save the second legend to the list.
- Continue this process of creating and saving until all legends are entered into your list.
11. To exit the current list, turn the power off.
- To exit (deactivate) a list, you can create a new list, select a list, or turn the power off.

Selecting a List

Selecting a List will make it active for printing and editing. To select a list, follow the instructions below:

1. Press **<List>** to activate the List Menu.
2. The cursor is on *Select*. Press **<Enter>**. You will be prompted with all list names stored in the printer (up to 10). The last activated list will display on the Text Editor screen.
3. Use the **<▲>** and **<▼>** keys to select the name of the list you want to activate, then press **<Enter>**. The part number you originally entered briefly displays, followed by the Text Editor screen.

Your list is now activated for printing or editing.

Printing a List

To print a list, follow the instructions below:

1. If you do not have a list active, create or select a list. Refer to *Create a New List* and *Selecting a List* earlier in this section for instructions.
2. Press **<List>** to access the List Menu.

You must go through the List Menu in order to print a list. Simply pressing **<Print>** will print only the legend shown in the Text Editor screen.

3. Press the **<▼>** key twice to select *Print*, then press **<Enter>**. If no list is active, “Invalid Function” is displayed on the Text Editor screen.
4. If a list is activated and you have recalled a legend, you are prompted to choose “Entire List” or “From Current”. Select “From Current” if you want to print only the part of the list from the legend currently displayed forward. If you run out of ribbon or markers during a list print, press **<Enter>** to return to the the legend where the printer stopped.

- At the prompt “No. of Copies?”, enter the number of times you want the active list to print (up to 250) and press **<Enter>**.

This is the number of copies of each label within the list. If two copies are requested, the labels will print in this order [1,1,2,2,3,3...]. You cannot print multiple copies of the list in this order [1,2,3,1,2,3...] from the *Print* option.

 **Note:** If a list is activated but no legends are recalled, the Print option goes directly to the “No. of Copies?” prompt.

Although a list is typically printed on the part it was created for, you can print the list using any part that has a printable area greater than or equal to the part for which the list was originally created in both the X and Y dimensions. However, if you try to print on a smaller label, the error message “Invalid Function” will display on the Text Editor screen.

Editing a List

Editing a list involves deleting legends from a list and changing characters in a legend already in a saved list.

There are two ways to edit an active list:

- If you have the correct part (the part the list was originally created for) installed in the printer, you can recall legends from the active list and then edit them the same way you would edit a non-list legend.
- If you do not have the correct part (or do not have any part) installed in the printer, you can still edit a list through Edit mode. Edit mode is explained later in this section.

To edit a list:

- Select the list that you want to edit. Refer to *Selecting a List* earlier in this section for instructions.

You cannot select a list unless the correct part (the part the list was created for) is loaded in the printer. If you try to select a list without the correct part loaded in the printer, or no part is loaded in the printer, this error message will display on the Text Editor screen:

The part your list
was created for. —————>

**Wrong Part! Use
PTL-XX-XXX**

***This message will only display if
the Edit mode is off.***

This message will also display if you are trying to save a legend to an active list, and the wrong part (a part other than the part the list was created for), or no part, is loaded in the printer.

 If you do not remember the correct part for the list you want to edit, place the cursor on your list name (after choosing *Select*), then press the **<>** key. The correct part displays on the Text Editor screen, **providing that you entered it when you created the list**. See *Creating a List* earlier in this section. Press the **<>** key to return to the list name. In order to delete or edit a legend in a list, you must recall the legend. When you activate a

list, the last legend you entered will display on the Text Editor screen. However, this does not mean that the legend is recalled.

2. Recall a legend from the active list.

- Press **<Func>+<Recall>** to recall the next legend in a list.
- Press **<Func>+<Shift>+<Recall>** to recall the previous legend in a list.

If you want to delete a legend:

Press **<Func>+<Shift>+<Delete>**. The legend is deleted from the active list.

If you want to change characters in a legend:

1. Edit the legend following the normal guidelines for non-list legends.

All style options for editing non-list legends can be used to edit legends within a list, and different legends can have different styles even though they belong to the same list. Style options include:

- H Justify
- V Justify
- Format
- Font Size
- Rotation

2. Press **<Func>+<Save>** to save the edited legend.

3. When the prompt appears “Save as New” or “Save as Current”, select “Save as Current”. Your edited legend is now saved to the list.

Selecting “Save as New” will add the legend to the end of the list. See *Appending a List* later in this section for details.

Using Edit Mode

The Edit mode can be toggled to *on* or *off*. Use the Edit mode within the List Menu to modify a list when:

- a part is not installed in the printer.
- or-
- a part other than the part the list was created for is installed in the printer.

To use Edit mode, follow the instructions below:

1. Press **<List>** to activate the List Menu.
2. Press the **<v>** key three times to select *Edit*, then press **<Enter>**
3. The Edit mode defaults to *Off*. Use the **<v>** key to select *On*, then press **<Enter>**.
4. You will be prompted with all list names stored in the printer (up to 10). Use the **<▲>** and **<▼>** keys to select the list you want to edit, then press **<Enter>**.

The Text Editor screen appears. The left and right arrows on the Status Bar (top line of the screen — see below) are replaced by lighting bolts to indicate that the Edit mode is on.

Text Editor screen with Edit mode *on*.



When in Edit mode, the Print, Feed, and Peel commands are disabled. Turn the Edit mode off to restore these functions.

The Edit mode toggles to *Off* when the printer is turned off.

Appending a List

To append a list means to add legends to a previously saved list. All legends are appended to the end of the list. You cannot save legends to the beginning or middle of a list.

1. If you do not have a list active, select a list. Refer to *Selecting a List* earlier in this section for instructions.
2. Create a legend following the normal guidelines for non-list legends.
3. Press **<Func>+<Save>**.
4. When the prompt appears “Save as New” or “Save as Current”, select “Save as New”. Your legend is now added to the end of the list.

Deleting a List

To delete a list from memory, follow the instructions below:

1. Press **<List>** to activate the List Menu.
2. Press the **<v>** key four times to select *Delete*, then press **<Enter>**. You will be prompted with all the list names stored in the printer (up to 10).
3. Use the **<▲>** and **<▼>** keys to select the name of the list you want to delete, then press **<Enter>**. After deleting a list, the display returns to the Text Editor screen.

Continuous Printing—Terminal Block Labels

This section discusses making terminal block labels with the TLS2200™ printer.

Creating Terminal Block Labels

Terminal block labels can be created and printed using the TLS2200 printer. Simply choose the appropriate center-to-center spacing repeat (pitch) for the block, enter your text, and print as needed. The number of lines of text available at each termination is dependent on repeat value spacing and the font size chosen.

Setting the Center-to-Center Spacing

The center-to-center spacing (terminal block repeat) is set by accessing the *Term Repeat* option on the Setup Menu. Follow the instructions below to set this option:

1. Press the **<Func>** + **<Setup>** keys to access the Setup Menu.
2. Press the **<▼>** key two times to scroll to the Continuous Menu, press the **<Enter>** key.
3. With the cursor on the *Terminal Block* option, press **<Enter>**.
4. Use the arrow keys to adjust the terminal block repeat value, then press **<Enter>**.

The repeat can be set from 2 mm (0.19685 in) to 46 mm (1.81102 in). Press the **<▲>** and **<▼>** keys to increase/decrease the repeat value by 0.125 mm increments (1 dot). Press the **<Shift>** + **<▲>** and **<Shift>** + **<▼>** to increase/decrease the repeat value by 1 mm increments (8 dots).



Note: Press **<Feed>** after printing to advance the terminal strip label to the cut position.

Continuous Printing—Banners

You can create banners using the TLS2200™ printer. Banners have a variety of industrial uses, including labeling larger conduit.

 New continuous label parts designed for banner printing such as PTL-8, PTL-42, and PTL-43 can only be used with version 2 software or higher. If you are using version 1 software, you will not be able to enter text on the editor screen. *Refer to **Error! Reference source not found.** for help with installing new software on your TLS2200 printer.*

To create a banner, complete the following steps:

1. Press the **<Func>** + **<Setup>** keys to access the Setup Menu.
2. Press the **<▼>** key twice to select *Continuous*, then press **<Enter>**.
3. Press the **<▼>** key once to select *Banner*, then press **<Enter>**.
4. Use the **<▲>** and **<▼>** keys to select the desired rotation, then press **<Enter>**.
5. Press **<Func>** + **<Exit>** to exit back to the Text Editor screen.
6. Enter the banner text as needed and print your label. The first banner label printed will have an additional 1” of material fed before the text prints. After the first banner label prints, press **<feed>** and then cut to avoid excess waste on subsequent labels.

Banner Rotation

Banners can be printed either horizontally or vertically.

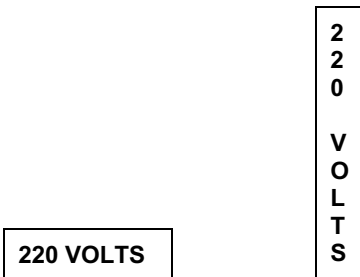

Horizontal Banner Vertical Banner

Default Font Size

For continuous printed labels (banners), the default font size is the largest font that prints on the selected marker width in horizontal orientation.

Fixed Length Banners

With the TLS2200 printer, you can specify a fixed length for the banner. Values range from a banner length of 26mm (1.02362 in) to a banner length of 312mm (12.28346 in).

You can set the banner length in increments of 1mm by pressing the **<Func>+<▲>** or **<▼>** keys.

Fixed length allows you to use the H Justify to specify at which point on the banner you want the text to appear. The H Justify option allows Left, Center, and Right justification.

Barcode Labels

This section discusses making barcode labels with the TLS2200™ printer.

Creating Barcode Labels

The TLS2200 printer allows you to create Code 39 barcodes for your labels. Legends made utilizing the bar-coding feature can consist of a single barcode, several barcodes, or barcodes together with text.

Setting Barcode Options

When adding a barcode to your label, several options can be accessed to customize how your barcode(s) are formatted and printed. Options available are as follows:

Legend Type: This setting is used to select the Legend Entry Mode. Pressing the **<Barcode>** key allows you to toggle between *Text* and *Barcode*. When set to *Barcode* mode, all text entered on the line/label print as a Code 39 barcode. The Status Bar (first line on the LCD) displays a *B* to indicate you are in Barcode mode.

Bar Height: This setting can be accessed from the Barcode submenu on the Setup Menu. This option allows you to set the height of your Code 39 barcode(s). Heights range from 1 to 26 millimeters and can be increased/decreased in 1-millimeter increments.

Human Readable: This setting is also accessed from the Barcode submenu on the Setup Menu. This option allows you to determine whether your barcode(s) are printed together with human readable text (toggles on and off). Barcode human readable text print at a font size of 2 (5 point) up to 9 (14 point).

Rotation: This option, located on the Setup sub-menu named *Style*, allows you to set the rotation of your barcode(s) in one of four orientations (0°, 90°, 180°, 270°). This allows you to create both picket fence and ladder style barcodes. Please note, however, that all lines on the legend (text and/or barcode) print at the rotation selected. Lines cannot be rotated independently.

Code 39 Barcode Symbology

The barcode symbology used by the TLS2200 printer is *Code 39*. The character set for this symbology consists of the following characters:

The capital letters: **A to Z**

The numbers: **0 to 9**
 The **space** character
 The symbols: **- . \$ / + %**

Characters entered in lowercase are automatically converted to uppercase when printed.

TLS2200 Printer Barcode Parameters

Symbology: Code 39
 Narrow Bar Width: 2 dots (.25mm)
 Wide-to-Narrow Ratio: 2 to 1
 Quiet Zone: 10 dots (1.25mm)
 Density 7.82 CPI

Maximum Barcode Characters

The maximum number of characters for a bar code is 25. The following table lists the maximum barcode characters per line:

Marker Width	Max # of Barcode Chars Per Line
12.7 mm (0.5 in.)	* 0
25.4 mm (1.0 in.)	4
38.1 mm (1.5 in.)	8

* Zero characters allowed on label (quiet zone and start/stop characters occupy entire width).

To create labels containing barcodes, follow the instructions below:

1. Press the **<Barcode>** key to toggle the legend type from *Text* to *Barcode* mode (*B* is displayed on the Status Bar).
2. Press the **<Func> + <Setup>** keys to access the Setup Menu.
3. Press the **<▼>** key once to select *Barcode*, then press **<Enter>**.
4. With the cursor highlighted on *Bar Height*, press **<Enter>**.
5. Use the **<▲>** and **<▼>** keys to set the height of your barcode(s), then press **<Enter>**.
6. Press the **<▼>** key once to select *Human Readable*, then press **<Enter>**.
7. Press the **<▲>** or **<▼>** keys to toggle the human readable text on or off as required, then press **<Enter>**.
8. If human readable, press the **<▲>** or **<▼>** keys to select the text font size desired, then press **<Enter>**.
9. Press the **<Delete>** key to back out one level in the Setup Menu tree.
10. Press the **<▼>** key twice to select *Style*, then press **<Enter>**.

11. With the cursor highlighted on *Rotation*, press **<Enter>**.
12. Use the **<▲ >** and **<▼ >** keys to select the desired rotation, then press **<Enter>**.
13. Press **<Func> + <Exit>** to exit back to the Text Editor screen.
14. Enter barcode text as needed and print your label.

Multiple Barcodes

Multiple barcodes can be entered on a label, but only one barcode can be entered per line. Bar height can be set to one height only per label regardless of the number of barcodes entered on the label.

Switching Between Text and Barcode Mode

Text already entered on a line can be switched from *Text* to *Barcode* mode and vice versa. If the size of the barcode or text being switched to does not fit on the label, you encounter the message “Reduce Type Size” when you attempt to print the label. You must scroll to the line where the switch was made, reduce the size of the font (if text) or bar height (if a barcode), and print again.



Note: You cannot switch the legend mode from *Text* to *Barcode* if a line contains any invalid Code 39 barcode characters.

Tutorial Guide

The following pages provide step-by-step instructions for creating and printing labels using a variety of different printer functions.

The part number of the marker roll used is noted at the beginning of each tutorial. Many of the tutorials use part number PTL-19-423. A sample roll of this 1" x 1" marker is provided in your TLS2200™ Thermal Labeling System package.

T1: Creating a One-Line Legend, Component Marker



Note: This example assumes you have marker roll **PTL-19-423** loaded in your printer.

Label to be printed:

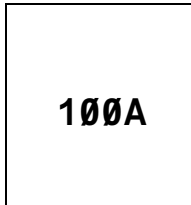

Setup Status:

H Justify	Center
V Justify	Center
Rotation	0 Degrees
Format	Component

1. Check the Status Bar to make sure the unit is in Component mode. If not, press **<Shift> + <Wire>** to toggle from Wiremarker mode to Component mode.
2. Enter **100A** on line one. (Font is set at default size - 9)
3. Press **<Print>**.

T2: Creating a Component Label Utilizing Multiple Font Sizes



Note: This example assumes you have marker roll **PTL-19-423** loaded in your printer.

Label to be printed:

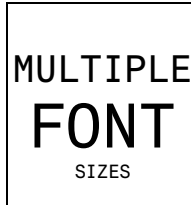

Setup Status:

H Justify	Center
V Justify	Center
Rotation	0 Degrees
Format	Component

1. Press **<Legend Clear>** to clear the text from line one.
2. With the font size set at the default of 9, enter **MULTIPLE** on line one, then press **<Enter>**.
3. Press **<Shift> + <▲>** three times to increase the font size to 12.
4. Enter **FONT** on line two, then press **<Enter>**.
5. Press **<Shift> + <▼>** eight times to decrease the font size from 12 to 4.
6. Enter **SIZES** on line three.
7. Press **<Print>**.

T3: Creating a Wiremarker



Note: This example assumes you have marker roll **PTL-19-423** loaded in your printer.

Label to be printed:

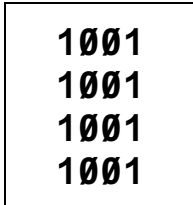

Setup Status:

H Justify	Center
V Justify	Center
Rotation	0 Degrees
Format	Component

1. Press **<Shift> + <Form Clear>** to delete all lines of text and reset the font to the default value of 9.
2. Press **<Shift> + <Wire>** to change format mode from *Component* to *Wire* (note the change from *C* to *W* on the LCD Status Bar).
3. Enter **1001** on line one.
4. Press **<Print>**.

T4: Creating Serialized Wiremarkers



Note: This example assumes you have marker roll **PTL-19-423** loaded in your printer.

Labels to be printed:

A201 A201 A201 A201
.
.
.
.
A205 A205 A205 A205

Setup Status:

H Justify	Center
V Justify	Center
Rotation	0 Degrees
Format	Wire

1. Press **<Legend Clear>** to clear the text from line one.
2. Check the Status Bar to make sure the unit is in Wiremarker mode. If not, press **<Shift>** + **<Wire>** to toggle from Component mode to Wiremarker mode.
3. Enter **A201** on line one.
4. Press **<Left>** to position the cursor under the last character.
5. Press **<Func>** + **<Serial>**.
6. When “No. to Serial?” prompt appears, enter **5**, then press **<Enter>**.

7. When “No. of Copies?” prompt appears, enter **2**.
8. Press **<Enter>** or **<Print>**. The printer begins printing two each of the five wiremarkers listed above.

T5: Creating a Label with Rotated Text, Printing Multiple Copies



Note: This example assumes you have marker roll **PTL-19-423** loaded in your printer.

Label to be printed:

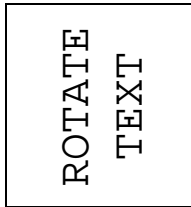

Setup Status:

H Justify	Center
V Justify	Center
Rotation	0 Degrees
Format	Component

1. Check the Status Bar to make sure the unit is in Component mode. If not, press **<Shift> + <Wire>** to toggle from Wiremarker mode to Component mode.
2. Press **<Shift> + <Form Clear>** to delete all lines of text and reset the font to the default size of 9.
3. Press **<Func> + <Setup>** to access the Setup Menu.
4. Press **<v>** three times to move to the Style sub-menu, then press **<Enter>**.
5. With the cursor highlighted on *Rotation*, press **<Enter>**.
6. Press the **<▲>** key once to select *90 Degrees*.
7. Press **<Enter>**.
8. Press **<Func> + <Exit>** to exit back to the text editor screen.
9. Press **<Shift> + <▲>** once to increase the font size to 10.
10. Enter **ROTATE** on line one, then press **<Enter>**.
11. Enter **TEXT** on line two.
12. Press **<Func>+<Multi Print>**.
13. When “No. of Copies?” prompt appears, enter **3**.
14. Press **<Enter>**. The printer prints three copies of the legend created above.

T6: Creating a Barcode Label



Note: This example assumes you have marker roll **PTL-19-423** loaded in your printer.

Label to be printed:

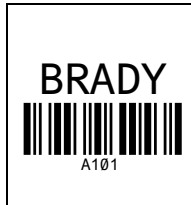

Setup Status:

H Justify	Center
V Justify	Center
Rotation	0 Degrees
Format	Component
Legend Type	Text

1. Press **<Shift> + <Form Clear>** to delete all lines of text and reset the font to the default value of 9.
2. Press **<Func> + <Setup>** to access the Setup Menu.
3. Press **<▼>** three times to move to the Style sub-menu, then press **<Enter>**.
4. With the cursor highlighted on *Rotation*, press **<Enter>**.
5. Press the **<▼>** key once to select *0 Degrees*.
6. Press **<Enter>**.
7. Press **<Delete>** to return to the Setup Menu.
8. Press the **<▲>** key twice to select *Barcode*, then press **<Enter>**.
9. With the cursor highlighted on *Bar Height*, press **<Enter>**.
10. Use the **<▲>** and **<▼>** keys as needed to set the height of your barcode to 8mm (0.31496 in.), then press **<Enter>**.
11. Press the **<▼>** key once to select *Human Readable*, then press **<Enter>**.
12. Press the **<▲>** or **<▼>** keys to toggle the human readable text ON, then press **<Enter>**.
13. Press the **<▲>** or **<▼>** keys as needed to set the font size to 3, then press **<Enter>**.
14. Press **<Func> + <Exit>** to exit back to the Text Editor screen.

15. With the cursor highlighted on line one, press **<Shift> + <▲>** two times to increase the font size from 9 to 11.
16. Enter **BRADY** on line one, then press **<Enter>**.
17. Press the **<Barcode>** key to toggle the Legend Type for line two from *Text* to *Barcode* mode (*B* is displayed on the Status Bar).
18. Enter **A101** on line two.
19. Press **<Print>**.

T7: Creating a Serialized Barcode Label



Note: This example assumes you have marker roll **PTL-19-423** loaded in your printer.

Labels to be printed:

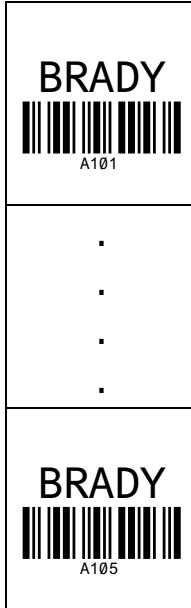

Setup Status:

H Justify	Center
V Justify	Center
Rotation	0 Degrees
Format	Component
Legend Type	Text

1. Repeat steps 1-17 from *Creating a Barcode Label*.
2. Press <Left> to position the cursor under the last character.
3. Press <Func> + <Serial>.
4. When “No. to Serial?” prompt appears, enter **5**, then press <Enter>.
5. When “No. of Copies?” prompt appears, enter **1**.
6. Press <Enter> or <Print>. The printer begins printing one each of the five serialized barcode labels from **A101** to **A105**.

T8: Creating a Terminal Block Label



Note: This example assumes you have the terminal block marker roll **PTLTB-400-375** loaded in your printer.

Label to be printed:

101
102
103
104
105
106
107
108
109
110

Setup Status:

H Justify	Center
V Justify	Center
Rotation	0 Degrees
Format	Component
Legend Type	Text

1. Press **<Shift> + <Form Clear>** to delete all lines of text and reset the font to the default value of 6.
2. Press **<Func> + <Setup>** to access the Setup Menu.
3. Press the **<▼>** key six times to select *Units*, then press **<Enter>**.
4. Press the **<▲>** or **<▼>** keys to toggle the Units to *Metric*, then press **<Enter>**.
5. Press the **<▲>** key four times to select *Continuous*, then press **<Enter>**.
6. With the cursor highlighted on *Terminal Block*, press **<Enter>**.
7. Use the **<▲>** and **<▼>** keys as needed to set the terminal block repeat value to 6 mm (.23622 in.), then press **<Enter>**.
8. Press **<Func> + <Exit>** to exit back to the Text Editor screen.

9. With the cursor highlighted on line one, press **<Shift> + <▲>** once to increase the font size from 6 to 7.
10. Enter **101** on line one.
11. Press **<◀>**.
12. Press **<Func> + <Serial>**.
13. When “No. to Serial?” prompt appears, enter **10**, then press **<Enter>**.
14. When “No. of Copies?” prompt appears, enter **1**.
15. Press **<Enter>** or **<Print>**. The printer should print ten times along the terminal block marker (**101** through **110**).
16. Press **<Feed>** to advance printed terminal strip label to the cut position.

T9: Creating a Patch Panel Label



Note: This example assumes you have the continuous marker roll **PTL-8-422** loaded in your printer.

Label to be printed:

C012
01D
C012
02D
C012
03D
C012
04D
C012
05D
C012
06D
C012
07D
C012
08D
C012
09D
C012
10D
C012
11D
C012
12D

Setup Status:

H Justify	Center
V Justify	Center
Rotation	0 Degrees
Format	Component
Legend Type	Text

1. Press **<Shift> + <Form Clear>** to delete all lines of text and reset the font to the default value of 14.
2. Press **<Func> + <Setup>** to access the Setup Menu.
3. Press the **<▼>** key six times to select *Units*, then press **<Enter>**.
4. Press the **<▲>** or **<▼>** keys to toggle the Units to *Inches*, then press **<Enter>**.
5. Press the **<▲>** key four times to select *Continuous*, then press **<Enter>**.
6. Press the **<▲>** key once to choose *Terminal Block*, then press **<Enter>**.
7. Use the **<▲>** and **<▼>** keys as needed to set the terminal block repeat value to 0.60039 (15.25 mm), then press **<Enter>**.
8. Press **<Func> + <Exit>** to exit back to the Text Editor screen.
9. With the cursor highlighted on line one, press **<Shift> + <▲>** once to increase the font size from 5 to 6.
10. Enter **C012** on line one, then press **<Enter>**.
11. Enter **01D** on line two.
12. Press the **<▲>** key twice.
13. Press **<Func> + <Serial>**.
14. When “No. to Serial?” prompt appears, enter **12**, then press **<Enter>**.
15. When “No. of Copies?” prompt appears, enter **1**.

16. Press **<Enter>** or **<Print>**. The printer should print twelve times along the patch panel label (**01D** through **12D**).
17. Press **<Feed>** to advance printed patch panel label to the cut position.

T10: Creating a Continuous Label



Note: This example assumes you have the continuous marker roll **PTL-8-422** loaded in your printer.

Print the following label to be used to identify communications equipment:

BX1.10H2CC 10 Base T HUB TO 2ND FLOOR CALL CENTER

Setup Status:

H Justify	Left
V Justify	Center
Rotation	0 Degrees
Format	Component
Legend Type	Text

1. Press **<Shift> + <Form Clear>** to delete all lines of text and reset the font to the default value of 14.
2. Press **<Func> + <Setup>** to access the Setup Menu.
3. Press the **<▼>** key three times to select *Style*, then press **<Enter>**.
4. Press the **<▼>** key once to select *H Justify*, then press **<Enter>**.
5. Press the **<▲>** or **<▼>** keys to select *Left*, then press **<Enter>**.
6. Press the **<Delete>** button to exit back to the Setup Menu.
7. Press the **<▲>** key once to select *Continuous*, then press **<Enter>**.
8. Press the **<▼>** key once to select *Banner*, then press **<Enter>**.
9. Press the **<▲>** or **<▼>** keys to toggle the direction to *Horizontal*, then press **<Enter>**.
10. Press **<Func> + <Exit>** to exit back to the Text Editor screen.
11. Enter **BX1.10H2CC 10 Base T HUB TO 2ND FLOOR CALL CENTER** on line one.
12. Press **<Print>**.

T11: Creating a Banner Label of Fixed Length



Note: This example assumes you have the banner marker roll **PTL-43-439OR** loaded in your printer.

Print the following label to be used to identify an electrical conduit:

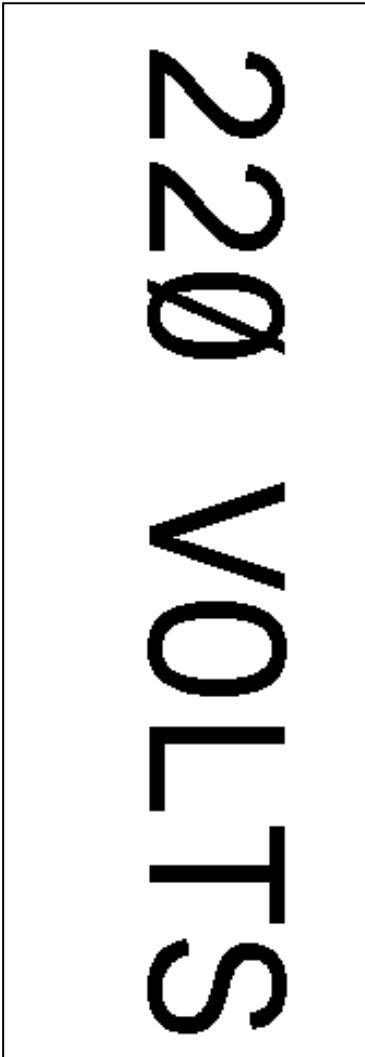

Setup Status:

H Justify	Center
V Justify	Center
Rotation	0 Degrees
Format	Component
Legend Type	Text

1. Press **<Shift> + <Form Clear>** to delete all lines of text and reset the font to the default value of 19.
2. Press **<Func> + <Setup>** to access the Setup Menu.
3. Press the **<▼>** key six times to select *Units*, then press **<Enter>**.
4. Press the **<▲>** or **<▼>** keys to toggle the Units to *Metric*, then press **<Enter>**.
5. Press the **<▲>** key four times to select *Continuous*, then press **<Enter>**.
6. Press the **<▼>** key once to select *Fixed Length*, then press **<Enter>**.
7. Use the **<▲>** and **<▼>** keys as needed to set the fixed length repeat value to 143.000mm (5.62992 inches), then press **<Enter>**.
8. Press **<Func> + <Exit>** to exit back to the Text Editor screen.
9. Enter **220 VOLTS** on line one.
10. Press **<Print>**.
11. Press **<Feed>** to advance the banner to the cut position.

T12: Creating a Legend List, Component Markers



Note: This example assumes you have marker roll **PTL-19-423** loaded in your printer.

Labels to be printed:

PANEL1
PANEL1A
PANEL2

Setup Status:

H Justify	Center
V Justify	Center
Rotation	0 Degrees
Format	Component
Legend Type	Text

1. Press **<List>**.
2. Press the **<v>** key once to select *Create*, then press **<Enter>**.
3. When “Enter List Name” prompt appears, enter LIST1, then press **<Enter>**.
4. When “Enter Part No.” prompt appears, enter PTL-19-423, then press **<Enter>**.
5. Press **<Shift> + <Form Clear>** to delete all lines of text and reset the font to the default value of 9.
6. Enter **PANEL1** on line one.
7. Press **<Func>+<Save>**.
8. Press **<Shift>+<Legend Clear>**.
9. Enter **PANEL1A** on line one.
10. Press **<Func>+<Save>**.

11. Press **<Shift>+<Legend Clear>**.
12. Enter **PANEL2** on line one.
13. Press **<Func>+<Save>**.
14. Press **<List>**.
15. Press the **<v>** key twice to select *Print*, then press **<Enter>**.
16. When the “No. of Copies?” prompt appears, enter **1**, then press **<Enter>**.

T13: Creating a Legend List Utilizing Multiple Font Sizes and Rotations.



Note: This example assumes you have marker roll **PTL-19-423** loaded in your printer.

Labels to be printed:

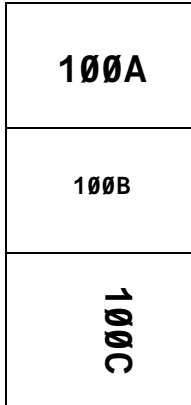

Setup Status:

H Justify	Center
V Justify	Center
Rotation	0 Degrees
Format	Component
Legend Type	Text

1. Press **<List>**.
2. Press the **<v>** key once to select *Create*, then press **<Enter>**.
3. When “Enter List Name” prompt appears, enter LIST2, then press **<Enter>**.
4. When “Enter Part No.” prompt appears, enter PTL-19-423, then press **<Enter>**.
5. Press **<Shift> + <Form Clear>** to delete all lines of text and reset the font to the default value of 9.
6. Enter **100A** on line one.
7. Press **<Func>+<Save>**.
- 8.
9. Press **<Shift>+<Legend Clear>**.Press **<Shift>+<v>** twice to reduce the font size to 7.

8. Enter **100B** on line one.
9. Press **<Func>+<Save>**.
10. Press **<Shift>+<Legend Clear>**.
11. Press **<Func>+<Setup>**.
12. Press the **<v>** three times to select *Style*, then press **<Enter>**.
13. With the cursor on *Rotation*, press **<Enter>**.
14. Press the **<A>** three times to toggle to *270 Degrees*, then press **<Enter>**.
15. Press **<Func>+<Exit>** to return to the Text Editor screen.
16. Enter **100C** on line one.
17. Press **<Func>+<Save>**.
18. Press **<List>**.
19. Press the **<v>** key twice to select *Print*, then press **<Enter>**.
20. When the “No. of Copies?” prompt appears, enter **1**, then press **<Enter>**.

T14: Creating a Legend List, Wiremarkers, Printing Multiple Copies



Note: This example assumes you have marker roll **PTL-19-423** loaded in your printer.

Labels to be printed:

<p>A1000 A1000 A1000 A1000</p>
<p>A2050 A2050 A2050 A2050</p>
<p>A2067 A2067 A2067 A2067</p>

Setup Status:

H Justify	Center
V Justify	Center
Rotation	0 Degrees
Format	Component

1. Press **<List>**.
2. Press the **<v>** key once to select *Create*, then press **<Enter>**.
3. When “Enter List Name” prompt appears, enter LIST3, then press **<Enter>**.
4. When “Enter Part No.” prompt appears, enter PTL-19-423, then press **<Enter>**.
5. Press **<Shift> + <Form Clear>** to delete all lines of text and reset the font to the default value of 9.
6. Press **<Func>+<Setup>**.
7. Press the **<v>** three times to select *Style*, then press **<Enter>**.
8. With the cursor on *Rotation*, press **<Enter>**.
9. Press the **<▲>** or **<v>** keys to toggle to *0 Degrees*, then press **<Enter>**.

10. Press **<Func>+<Exit>** to return to the Text Editor screen.
11. Press **<Shift> + <Wire>** to change format mode from *Component* to *Wire* (note the change from *C* to *W* on the LCD Status Bar).
12. Enter **A1000** on line one.
13. Press **<Func>+<Save>**.
14. Press **<Shift>+<Legend Clear>**.
15. Enter **A2050** on line one.
16. Press **<Func>+<Save>**.
17. Press **<Shift>+<Legend Clear>**.
18. Enter **A2067** on line one.
19. Press **<Func>+<Save>**.
20. Press **<List>**.
21. Press the **<v>** key twice to select *Print*, then press **<Enter>**.
22. When the “No. of Copies?” prompt appears, enter **2**, then press **<Enter>**.

T15: Creating and Recalling a Legend List, Barcode Labels



Note: This example assumes you have marker roll **PTL-19-423** loaded in your printer.

Labels to be printed:

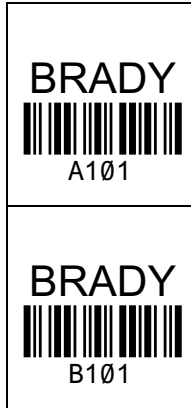

Setup Status:

H Justify	Center
V Justify	Center
Rotation	0 Degrees
Format	Component
Legend Type	Text

1. Press **<List>**.
2. Press the **<v>** key once to select *Create*, then press **<Enter>**.
3. When “Enter List Name” prompt appears, enter LIST4, then press **<Enter>**.
4. When “Enter Part No.” prompt appears, enter PTL-19-423, then press **<Enter>**.
5. Press **<Shift>** + **<Form Clear>** to delete all lines of text and reset the font to the default value of 9.
6. Press **<Func>** + **<Setup>** to access the Setup Menu.
7. Press the **<v>** key once to select *Barcode*, then press **<Enter>**.
8. With the cursor highlighted on *Bar Height*, press **<Enter>**.
9. Use the **<▲>** and **<▼>** keys as needed to set the height of your barcode to 8mm (0.31496 in.), then press **<Enter>**.

10. Press the <▼> key once to select *Human Readable*, then press <Enter>.
11. Press the <▲> or <▼> keys to toggle the human readable text *ON*, then press <Enter>.
12. Press the <▲> or <▼> keys as needed to set the font size to 6, then press <Enter>.
13. Press <Func> + <Exit> to exit back to the Text Editor screen.
14. With the cursor highlighted on line one, press <Shift> + <▲> two times to increase the font size from 9 to 11.
15. Enter **BRADY** on line one, then press <Enter>.
16. Press the <Barcode> key to toggle the Legend Type for line two from *Text* to *Barcode* mode (*B* is displayed on the Status Bar).
17. Enter **A101** on line two.
18. Press <Func>+<Save>.
19. Press <Legend Clear> to clear text from line 2 only.
20. Enter **B101** on line two.
21. Press <Func>+<Save>.
22. Turn the battery power switch *off* to deactivate List4.

To select (recall) List4 as the active list:

1. Turn the battery power switch *on*.
2. Press <List>.
3. With the cursor on *Select*, press <Enter>.
4. Use the <▲> and <▼> arrows to select List4, then press <Enter>. The part number appears, followed by the Text Editor screen. List4 is now the active list.
5. Press <List>.
6. Press the <▼> key twice to select *Print*, then press <Enter>.
7. When the “No. of Copies?” prompt appears, enter **1**, then press <Enter>.

T16: Creating a Legend List, Recalling and Editing a Legend



Note: This example assumes you have marker roll **PTL-19-423** loaded in your printer.

Labels to be printed:

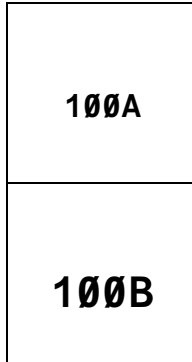

Setup Status:

H Justify	Center
V Justify	Center
Rotation	0 Degrees
Format	Component
Legend Type	Text

1. Press **<List>**.
2. Press the **<v>** key once to select *Create*, then press **<Enter>**.
3. When “Enter List Name” prompt appears, enter LIST5, then press **<Enter>**.
4. When “Enter Part No.” prompt appears, enter PTL-19-423, then press **<Enter>**.
5. Press **<Shift> + <Form Clear>** to delete all lines of text and reset the font to the default value of 9.
6. Enter **100A** on line one.
7. Press **<Func>+<Save>**.
8. Press **<Shift>+<Legend Clear>**.
9. Enter **100B** on line one.

10. Press **<Func>+<Save>**.
11. Turn the battery power switch *off* to deactivate List5.

To select (recall) List5 as the active list:

1. Turn the battery power switch *on*.
2. Press **<List>**.
3. With the cursor on *Select*, press **<Enter>**.
4. Use the **<▲>** and **<▼>** arrows to select List5, then press **<Enter>**. The part number appears, followed by the Text Editor screen.

To add a legend to List5:

1. Press **<Shift> + <Form Clear>** to delete all lines of text and reset the font to the default value of 9.
2. Enter **100C** on line one.
3. Press **<Func>+<Save>**. The legend is added (or *appended*) to the end of List5.

To recall and edit a legend already saved in List5:

1. Press **<Func>+<Recall>** twice to recall the second legend to the Text Editor screen. Legend 100B displays on the Text Editor screen.
2. Press **<Shift>+<▲>** four times to set the font size to 13.
3. Press **<Func>+<Save>**.
4. When the prompt appears “Save as New” or “Save as Current”, press the **<▼>** key once to select “Save as Current”.
5. Press **<Enter>**. Legend 100B is edited to a larger font size.

To delete a legend already saved in List5.

1. Press **<Func>+<Recall>**. Legend 100C displays on the Test Editor screen.
2. Press **<Func>+<Shift>+<Delete>**. Legend 100C is now deleted from List5.
3. Press **<List>**.
4. Press the **<▼>** key twice to select *Print*, then press **<Enter>**.
5. When the “No. of Copies?” prompt appears, enter **1**, then press **<Enter>**.

T17: Creating a Legend List, Banner Legends



Note: This example assumes you have the banner marker roll **PTL-42-439OR** loaded in your printer.

120 VOLTS CAUTION COMMUNICATIONS CLOSET

Setup Status:

H Justify	Center
V Justify	Center
Rotation	0 Degrees
Format	Component
Legend Type	Text

1. Press **<List>**.
2. Press the **<v>** key once to select *Create*, then press **<Enter>**.
3. When “Enter List Name” prompt appears, enter LIST6, then press **<Enter>**.
4. When “Enter Part No.” prompt appears, enter PTL-42-439, then press **<Enter>**.
5. Press **<Shift> + <Form Clear>** to delete all lines of text and reset the font to the default value of 18.
6. Press **<Func> + <Setup>** to access the Setup Menu.
7. Press the **<v>** key six times to select *Units*, then press **<Enter>**.
8. Press the **<A>** or **<V>** keys to toggle the Units to *Metric*, then press **<Enter>**.
9. Press the **<A>** key four times to select *Continuous*, then press **<Enter>**.
10. With the cursor highlighted on *Banner*, press **<Enter>**.
11. Press **<Func> + <Exit>** to exit back to the Text Editor screen.
12. Enter **120 VOLTS** on line one.
13. Press **<Func>+<Save>**.
14. Press **<Shift>+<Legend Clear>**.
15. Enter **CAUTION** on line one.
16. Press **<Func>+<Save>**.
17. Press **<Shift>+<Legend Clear>**.
18. Enter **COMMUNICATIONS CLOSET** on line one.

19. Press **<Func>+<Save>**.
20. Press **<List>**.
21. Press the **<v>** key twice to select *Print*, then press **<Enter>**.
22. When the “No. of Copies?” prompt appears, enter **1**, then press **<Enter>**.

Maintenance

Keep the TLS2200™ printer in good operating condition by performing the following recommended maintenance procedures.

Cleaning the Drive Roller and Cutter

Follow the instructions on the cleaning card shipped with the unit.

Cleaning the Print Head

Remove the cutter mechanism by loosening the screw that holds it in place. Lift the cutter away from the top of the printer mechanism and clean the print head with a cotton swab dipped in isopropyl alcohol. Replace the cutter mechanism.

Accessory Parts List

The following parts and accessories can be ordered from your BRADY Worldwide, Inc. supplier:

Description	Stock No.	NAED No.
AC Adapter	TLS2200-AC	18555
Battery Charger	TLS2200-BC	18551
Battery Pack	TLS2200-BP	18554
Cleaning Kit	PCK-5	18556
Communications Cable	TLS2200-CABLE	18574
Cutter Assembly	TLS2200-C	33897
Dust Cover	TLS2200-DC	18553
Hard Side Carrying Case	TLS2200-HC	18552
R4310 Black Ribbon	R4310	18558
R6010 Black Ribbon	R6010	18559
R6210 Black Ribbon	R6210	18560
R4410 Red Ribbon	R4410R	18704
R4410 White Ribbon	R4410W	18705
R4410 Blue Ribbon	R4410B	18706
Soft Side User's Case	TLS2200-SC	18562
User's Guide	TLS2200-UM	18557

Appendix 1: Troubleshooting and Error Message Guide

If your TLS2200™ printer is not performing as documented in this user’s guide, use the following troubleshooting and error message guides to determine the corrective action you should take. If the corrective action does not work, contact BRADY’s Technical Support Group.

Troubleshooting Guide

Symptom	Cause	Corrective Action
Poor quality printing.	Incorrect marker material/ribbon combination.	Verify the correct ribbon for the marker roll is loaded in the printer. Refer to the Ribbon Cross Reference Guide chart that came with the TLS2200 printer for proper ribbon selection.
Printer does not power up when turned on.	Battery pack is not charged.	<ol style="list-style-type: none"> 1. Connect the battery charger to the battery pack. 2. Charge the battery pack for at least five hours before operating solely on battery power.
	Battery pack may be worn out.	Battery life is approximately one to three years depending on its use and care. Order a replacement battery pack. Refer to page 11 for information on disposal of the battery pack.
Printer will not feed labels.	The marker roll has been fed through the material guide slots before the print head has been closed.	<ol style="list-style-type: none"> 1. Unlock the ribbon cartridge locking lever to open the print head, then remove the marker material from the material guide slots. 2. Close the print head by locking the ribbon cartridge lever 3. Feed the markers through the material guide slots.
	The leading edge of the marker roll is not inserted all the way to the drive roller.	Feed the leading edge of the marker roll through the material guide slots until you meet resistance.
	The leading edge of the marker roll is uneven or torn (not a straight edge).	Use a pair of scissors to cut a straight leading edge on the marker roll.
Top of the marker is cut through when cutting PSPT markers.	The movable material guide is not fully locked in place.	Verify the movable material guide is fully locked into the proper notch in the guide plate.

Error Messages

Error Message	Cause	Corrective Action
Error in Checksum	The software was improperly installed on your TLS2200™ printer.	Contact BRADY's Technical Support Group.
Error Head Open	Print head is unlocked.	<ol style="list-style-type: none"> 1. Move the lever on the right side of the TLS2200 printer to the lock position. 2. Press the <Enter> or <Delete> button to clear the display.
Error No Label Present	The TLS2200 printer is not seeing the marker's smart cell located on the side of the marker roll.	<ol style="list-style-type: none"> 1. Verify the smart cell is making contact with the left material guide. 2. Be sure the right material guide is adjusted as far to the left as possible for the roll of markers used. The material guide should be locked into the proper notch in the guide plate. 3. Be sure the marker roll is snapped evenly and firmly in the label roll cradle. 4. Press the <Enter> or <Delete> button to clear the display.
Error Out of Label	The roll of markers is inserted properly in the material guides, however, they are either not feeding properly or the roll has run out of markers.	<ol style="list-style-type: none"> 1. Press the <Enter> or <Delete> button to clear the display. 2. Install a new marker roll if the roll has run out. <p>If:</p> <ul style="list-style-type: none"> • you have not run out of markers, the markers are not feeding properly. Be sure to insert the leading edge of the markers into the material path until they hit the feed roller. Be sure the leading edge of the marker is straight. If not, cut the edge with a pair of scissors. • the markers are present and printing, they may have become skewed or jammed. To fix, press the <Feed> key to recalibrate or open the print head and pull the markers through to clear the jam.
Head Too Hot	Print head cannot reliably print due to heat buildup.	<ol style="list-style-type: none"> 1. Press the <Enter> or <Delete> button to clear the display. 2. Allow the printer to cool for ten minutes before printing labels.

Error Message	Cause	Corrective Action
Invalid Label	The marker roll may be running through the printer twice.	The smart cell is programmed to run 125% of the total number of markers on the roll and then stop. Insert a new marker roll and continue.
	Smart cell may not be programmed properly.	Contact BRADY's Technical Support Group.
Lithium Cell Low	Memory backup battery is low.	Contact BRADY's Technical Support Group.
Low Battery	Battery pack is not charged.	<ol style="list-style-type: none"> 1. Connect the battery charger to the battery pack. 2. Charge the battery pack for at least five hours before operating solely on battery power.
	Battery pack may be worn out.	Battery life is approximately one to three years depending on its use and care. Order a replacement battery pack. Refer to page 11 for information on disposal of the battery pack.
Out of Ribbon	The ribbon has run out.	Change the ribbon.
	The ribbon is folded or mangled due to improper installation or label jam.	<ol style="list-style-type: none"> 1. Remove the ribbon. 2. Manually advance the take-up spool end towards you until the ribbon has a smooth, flat surface. 3. Reinsert the ribbon in the printer.
	There is a bad ribbon sensor.	Contact BRADY's Technical Support Group.
Reduce Type Size	If you receive this message while typing, the line is full.	Press <Shift> + <▼> to reduce the font size to add more characters to the line.
	If you receive this message when you press <print> , you have exceeded the marker height. This occurs when font sizes are increased between lines of text, or you have chosen a bar code height that is too tall.	Reduce the font size or bar code height and press <print> again.

Error Message	Cause	Corrective Action
Memory Full	If you receive this message when trying to create a list, there are ten lists (the maximum) already saved in memory, or the memory has reached capacity.	Delete one or more lists.
	If you receive this message while trying to save a legend to a list, the memory has reached capacity.	Delete one or more lists or legends.
Wrong Part! Use PTL-XX-XXX	If you receive this message while trying to select a list, and Edit mode is off, either: <ul style="list-style-type: none"> •there is no part loaded in the printer. -or- •you have the wrong part loaded in the printer. The wrong part is a part other than the one the list was created for.	Load the correct part in the printer. The correct part is the part that the list was created for.
	If you receive this message while trying to save a legend to an active list, either: <ul style="list-style-type: none"> •there is no part loaded in the printer. -or- •you have the wrong part loaded in the printer. The wrong part is a part other than the one the list was created for.	Load the correct part in the printer. The correct part is the part that the list was created for.



Note: The error message “Invalid Function” may appear while you are working with legend lists. See Legend Lists on page 37 for details on working with lists. This error message may have different causes depending on what you are trying to do. The following table lists the different causes for this message as well as corrective action for each.

Error Message	Cause	Corrective Action
Invalid Function	If you receive this message while trying to enter Edit mode, you do not have a saved list.	Create a list. See Legend Lists on page 37 for instructions.
	If you receive this message while trying to print, you are in Edit mode.	Turn Edit mode <i>off</i> . See Legend Lists on page 37 for instructions.
	If you receive this message while trying to print and you are NOT in Edit mode, you do not have an active list.	Create or activate a list. See Legend Lists on page 37 for instructions.
	If you receive this message while trying to create a list, you are in Edit mode.	Turn Edit mode <i>off</i> . See Legend Lists on page 37 for instructions.
	If you receive this message while trying to delete a legend, you do not have a recalled legend.	Recall the legend that you want to delete. See Legend Lists on page 37 for instructions.
	If you receive this message while trying to save a legend to a list, you do not have an active list.	Create or activate a list. See Legend Lists on page 37 for instructions.

Appendix 2: Glossary of Terms

It may be helpful to review these terms while using this guide:

Active Legend List— A list becomes active when you create or select it. A list that has been activated is ready to be printed or edited.

Label—Once a marker contains printed text, it is referred to as a label.

Legend—The actual text to be printed on a marker. The legend appears on the LCD screen and can be stored in memory.

Legend List—One or more legends stored under a list name.

Marker—A blank label. Until a label is actually printed, the material is referred to as a marker. Markers are available in a variety of sizes.

Marker Roll—A marker roll contains the marker and a notched liner which are fed through the printer, and a smart cell located in the spindle. The TLS2200™ printer uses the smart cell to automatically identify the marker being used.

Recalled Legend— A legend is recalled when you press <Func>+<Recall> or <Func>+<Shift>+<Recall> from within an active legend list.

Serialize—To automatically print labels in a numeric or alphabetical sequence.

Appendix 3: Direct Printing from LabelMark/Win™

Use the LabelMark/WIN™ software to print labels from a PC through the TLS2200™ Thermal Transfer Printer. For more information on LabelMark/WIN™ software, please visit our website at www.bradyid.com.

